

CORTEX®



2023 CATALOGUE

**BETTER.
FASTER.
STRONGER.**



CORTEX®

STRENGTH

POWER RACKS & TOWERS	4
GYM STATIONS	7
EXERCISE BENCHES	12
LEG PRESS	14

WEIGHTS

OLYMPIC BARS & WEIGHTS	15
OLYMPIC BARS & ACCESSORIES	16
WEIGHT TRAINING ACCESSORIES	17
STANDARD BARS & WEIGHTS	19
KETTLEBELLS	21
DUMBBELLS	22

FUNCTIONAL TRAINING

PLYOMETRIC BOXES	24
WEIGHT BALLS & BAGS	25

REHABILITATION

ACCESSORIES	28
RESISTANCE BANDS	29
YOGA & THERAPY	30

PR-2 HALF RACK



POWERRACKPR2

Versatile half-rack designed for Olympic and standard barbells.

- Wide grip pull up handles
- Resistance band pegs
- 4 x Weight storage sleeves
- 2 x Olympic barbell storage slots
- Assembled dimensions:
165cm x 131.3cm x 233.3cm (L x W x H)

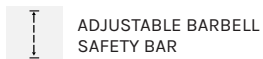

AVAILABLE IN PACKAGES:

PR-2 Half Rack Home Gym Package
CSST-PR2SET-B

PR-2 Half Rack & BN-6 Bench Package
CSST-PR2SET-C

**PR-2 Half Rack & BN-6 Bench Package +
90kg Standard Tri-Grip Weight Set**
CSST-PR2SET-D

PR-3 POWER RACK

POWERTOWERPT1

- Built for Barbell Squats, Bench Press
- Adjustable Barbell Hooks
- Dip Attachment
- Assembled dimensions:
173.5cm x 173.2cm x 228cm (L x W x H)



PT-1 POWER TOWER

POWERTOWERPT1

Versatile 4-way power tower for a big range of exercises.

Great for:

- Dips
- Leg raises
- Vertical knee raises
- Chin ups/pull ups
- Push ups
- Assembled dimensions:
140cm x 105cm x 216cm (L x W x H)





SR-1 SQUAT RACK

SQUATRACKSR1

Our squat stands are great for barbell bench press, back & front squats, shoulder press and more.

- Adjustable stand width
- Can be used for dips
- Assembled dimensions: 187cm x 52cm x 177cm (L x W x H)



ADJUSTABLE
BARBELL
SAFETY BAR



HEAVY DUTY
STEEL TUBING



ADJUSTABLE
J HOOKS

AVAILABLE IN PACKAGES:

**SR-1 Squat Rack & BN-6
Bench Package**
CSST-SR1SET-A

SR-3 SQUAT RACK

CSST-SR3

Solid, strong, and tall 1.8m squat rack. Perfect for squats, bench press, military shoulder press, and many more

- 40cm safety spots
- Resistance band pegs
- Assembled dimensions: 100cm x 160.9cm x 200cm (L x W x H)



ADJUSTABLE BARBELL
SAFETY BAR



HEAVY DUTY
STEEL TUBING



ADJUSTABLE
J HOOKS

AVAILABLE IN PACKAGES:

**SR-3 Squat Rack 95kg
Home Gym Package**
CSST-SR3SET-A



PULL UP BAR

Enhance your training sessions with the addition of a pull up bar.

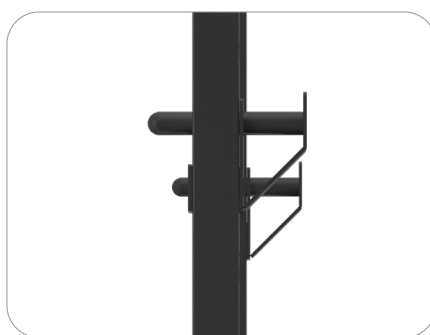

ADJUSTABLE J HOOKS

Load weights safely with your bar balanced in secure J Hooks. Adjust your hooks up to the maximum squat rack height of 1.8m and find the most comfortable height for whatever exercise you're performing.

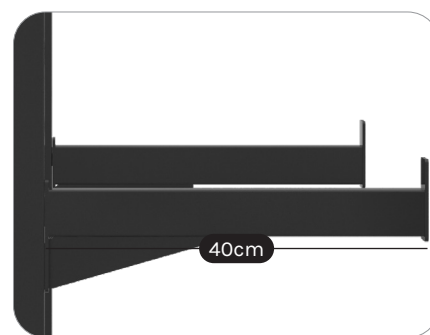

40CM LONG SAFETY SPOTS

Rely on 40cm long safety spot bars to catch the bar if you run out of energy on your last rep.

FT-40 CABLE CROSSOVER STATION

STATIONFT40

- Plug pin coupling for quick selection of the weight load in steps of 5kg
- Weights with aperture as injury protection
- 17 hole notches each with 10cm distance from the positioning of the pull handles
- Carabiner connection for easy exchange of pull handles: lateral/longitudinal grip or leg cuff
- Includes 2.1m high pull-up bar with varied grip lengths and opportunities
- Beginner to athlete
- Assembled dimensions: 112cm x 201cm x 213cm (L x W x H)

Includes:

- 1 x Cable pull station (assembly kit)
- 36 x 5 kg weight plate
- 1 x lengthwise pull bar
- 2 x T-handle



 75+ EXERCISES

 180KG WEIGHT RANGE

 STRONG STEEL FRAME



FEEL THE BURN THROUGH 75+ EXERCISES

Isolate specific muscle groups or focus on endurance exercises. Find the ultimate variety of home gym strength training with more than 75 available exercises.



STRONG CONSTRUCTION

Constructed from a solid steel square tube and with a heavy net weight, working out on the FT40 is always stable and secure. All parts are either powder-coated or chromed, giving the FT40 superior protection from scratches, corrosion, and rust.



90kg x 2
Adjustable at
5kg increments

HUGE 180KG WEIGHT RANGE

Two stacks, each weighing 90kg, supply you with a huge 180kg grand total weight. Weights increase in 5kg increments to give you ultimate specificity for each exercise.

SS2 SINGLE STATION

STATIONSS2

- 73.5kg weight stack (expandable)
- Height Adjustable Preacher Pad for Bicep Curls
- Workout diagram chart provided
- Basic attachments included

Assembled dimensions:
188cm x 103cm x 217cm (L x W x H)



CUSTOMISABLE WEIGHT STACK



38+ EXERCISES FOR A FULL BODY WORKOUT



2000LB TENSILE STRENGTH CABLES

*Additional 25kg Weight Stack can be purchased additionally.

25kg Weight Stack Optional Upgrade Kit (SS2/GS6)
WPSCONC25-SET



Upper Cable Attachment



Middle Cable Attachment



Lower Cable Attachment



Lat Pull Down Bar

Chest Press / Flys

Preacher Pad

73.5kg Weight Stack

Leg Extension

ALPHA SERIES FIXED BARBELL SET 100KG + STAND

CSBB-STD100

- Comes with 10kg, 15kg, 20kg, 25kg and 30kg fixed weight barbells
- Commercial Grade construction
- Includes 5-Tier Barbell Rack

01 ALPHA Series Fixed Barbell Stand L05
CXCAFBRACK05

02 Alpha Series Fixed Barbell Set 100kg
BBFIXSET100



HUGE VARIETY OF EXERCISES



STRONG STEEL FRAME



SS3 SINGLE STATION

CSST-SS3

With over 36 exercise options the SS3 Single Station's compact design is the perfect accessory for any home gym.

- 36+ Exercises for a full body workout
- Lat Pulldown Bar, Curl Bar, Tricep Rope, Single Handle, Straight Row Bar and Ankle Straps
- Assembled dimensions: 178.2cm x 105cm x 211.5cm (L x W x H)

 HEIGHT ADJUSTABLE SEAT & PREACHER PAD

 2000LB TENSILE CABLES

 73KG CUSTOMISABLE WEIGHT STACK

*Additional 25kg Weight Stack can be purchased additionally,

25kg Weight Stack Optional Upgrade Kit (SS3)

WPSCONC25-SET2



HEAVY DUTY CABLES

Rated to 2000lb of tensile strength.



DELUXE PADDING & STITCHING





The perfect amount of cushioning supported by strong stitching for any type of exercise.









STANDARD ATTACHMENTS INCLUDED

Alternate between the Tricep Rope, Lat Pulldown Curl Bar and Ankle Strap to perform a range of exercises.

GYM STATION ATTACHMENTS

	Close Grip V Handle ATTACHVTRIANGLE
	D Bar ATTACHDBAR
	Lat Pulldown Bar ATTACHLATPULLDOWNBAR
	Cable Curl Bar ATTACHCABLECURLBAR

	D Stirrup Handle ATTACHDSTIRRUPHANDLE
	Revolving Straight Bar ATTACHREVOLVESTRAIGHTBAR
	D Handle Row Bar ATTACHDROW
	25kg Weight Stack Addon for GS6/SS2 WPSCONC25-SET

	Tricep Rope ATTACHTRICEPROPE
	Tri Pushdown Bar ATTACHTRIPRESSBAR
	D Handle Wide Row Bar ATTACHDWROW

SM-20 6-IN-1 POWER RACK WITH SMITH & CABLE MACHINE

CSST-SM20

- 2.0m Smith Machine with 10-Level Height Adjustable Spotters
- 10 Level Adjustable Front Padded J-Hooks and Spot Bars
- Two Height Adjustable Cable Crossover Pulleys
- Barbell & 4 Weight Plate Storage
- 45kg Weight stack, expandable to 100kg with Weight plates
- Chin up/Pull Up Bar
- Landmine Attachment And Footplate for Seated Rows
- Assembled Dimensions: 203cm x 171cm x 211cm (L x W x H)



COMPATIBLE WITH OLYMPIC & STANDARD PLATES



45KG WEIGHT STACK EXPANDABLE UP TO 100KG



STRONG STEEL FRAME

AVAILABLE IN PACKAGES:

SM-20 6-in-1 Power Rack with Smith & Cable Machine + BN-6 Bench + 100kg Olympic Tri-Grip Weight Plate & Barbell Package
CSST-SM20-A





SM-10 CABLE & SMITH MACHINE

STATIONSM10SET

- Smith Machine with Linear Bearings
- 9 Smith Bar Hook Points
- Integrated Cable Machine
- Smith safety spot bars
- Chin-up Bar: 300kg Max Weight
- Cable Machine: 200kg Max Weight
- Dip Attachment: 250kg Max Weight
- Smith Machine: 300kg Max Weight
- Assembled dimensions: 199cm x 136cm x 212cm (L x W x H)



ADJUSTABLE
DIP HANDLES



HUGE VARIETY
OF EXERCISES



STRONG STEEL
FRAME

FT-11 PLATE LOADED CABLE CROSSOVER STATION

CSST-FT11

Structured with strong commercial grade steel, the FT-11 is designed to last workout after workout.

- Two Individual Weight Intake (50mm Weight Plate Hole Compatible)
- Max Weight of 80kg per intake/side
- Assembled dimensions: 296cm x 156cm x 223.7cm (L x W x H)



COMPATIBLE WITH
OLYMPIC WEIGHT PLATES



STRONG
STEEL FRAME



MAX WEIGHT OF 80KG
PER INTAKE/SIDE

AVAILABLE IN PACKAGES:

**FT-11 Plate Loaded Cable Crossover Station
with 115kg Olympic Tri-Grip Weight Set**
CSST-FT11-A



GS6 GYM STATION

STATIONGS6

- 73.5kg Weight Stack (Expandable)
- Height adjustable seat and preacher pad
- Workout diagram chart provided
- Free-standing and foldable ab bench
- Integrated power tower
- Basic attachments included



CUSTOMISABLE WEIGHT STACK



250KG MAX BODY WEIGHT



2000LB TENSILE STRENGTH CABLES

AVAILABLE IN PACKAGES:

GS6 Pro Gym Package
STATIONGS6-PRO

GS6 Ultimate Gym Package
STATIONGS6-ULTIMATE

GS6 Ultimate Gym + 90kg Standard Tri-Grip Weight & Bar Package
STATIONGS6-A



▶ SCAN QR FOR DEMO VIDEO



Assembled dimensions: 211cm x 163cm x 230cm (L x W x H)

*Additional 25kg Weight Stack can be purchased, or included if purchasing GS6 Ultimate Gym Package.

25kg Weight Stack Optional Upgrade Kit (SS2/GS6)
WPSCONC25-SET

BN-6 EXERCISE BENCH

BENCHBN6

- Fully adjustable bench with six levels (flat, incline, decline)
- Modular attachments for dip/chin ups
- High density padding
- Assembled dimensions: 144cm x 51cm x 115cm (L x W x H)

 ADJUSTABLE SEAT HEIGHT (2 LEVELS)

 HEAVY DUTY STEEL TUBING



 SCAN QR FOR DEMO VIDEO



BENCHBN6-SET

- Set includes chin up attachment and dip attachment



BENCHBN6CUP



BENCHBN6DIP

BN-7 FLAT EXERCISE BENCH

BENCHFLAT

- Wide and long backrest to assist user stability during workouts
- Wide and rubber footing base plate for bench stability
- High Density padding
- Assembled dimensions: 132cm x 67cm x 49cm (L x W x H)

 HUGE VARIETY OF EXERCISES

 HEAVY DUTY STEEL TUBING



 SCAN QR FOR DEMO VIDEO



BN-8 PREACHER PAD

BENCHPREACH

- Target Biceps and Arm Muscles
- Adjustable seat height
- High density padding
- Assembled dimensions: 89cm x 70.5cm x 87.5cm (L x W x H)

 ADJUSTABLE SEAT HEIGHT

 HEAVY DUTY STEEL TUBING

AVAILABLE IN PACKAGES:

BN-8 Preacher Pad + 84kg Standard Tri-Grip Weight Plate & Curl Bar Package
CSBN-BNPRCH-A



BN-11 EXERCISE FID BENCH WITH PREACHER PAD & LEG EXTENSION

CSST-BENCHBN11

Undertake a range of exercises on the BN-11 Exercise FID Bench with Preacher Pad and Leg Extension.

- Fully adjustable from decline, flat and incline positions (7 levels)
- 3 Seat Angle Adjustments
- Leg Extension and Leg Curl with Standing Bicep Curl Bar
- Leg Extension compatible with Olympic 50mm or Standard 25mm Weight Plates

 250KG MAX WEIGHT

 DELUXE PADDING & STITCHING



 SCAN QR FOR DEMO VIDEO

AVAILABLE IN PACKAGES:

BN-11 Exercise FID Bench + 79kg Standard Tri-Grip Weight Plate and Dumbbell Package
CSBN-BN11-A

BN-11 Exercise FID Bench + 85kg Olympic Tri-Grip Weight Plate and Dumbbell Package
CSBN-BN11-B



MF410 MULTIFUNCTION BENCH PRESS

CSST-MF410

Perfect for muscle building training the MF-410 Multifunction Bench Press targets the chest and upper body muscles.

- 9 Adjustable Levels of Flat and Incline
- 3 Seat Angle Adjustments
- Height Adjustable Barbell Holders



BARBELL HOOKS



SAFETY SPOTS

AVAILABLE IN PACKAGES:

MF410 MultiFunction Bench Press + 100kg Olympic Tri-Grip Weight Plate & Barbell Package
CSST-MF410-A

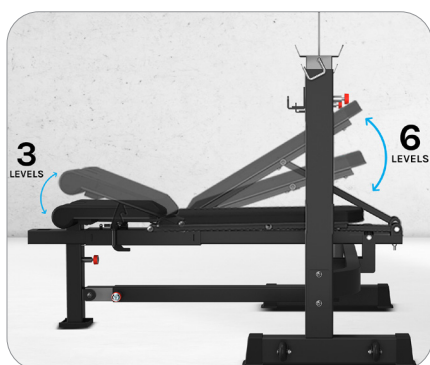

MULTI POSITION BENCH AND SEAT ANGLE

Benefit from the maximum amount of variety your bench press has to offer. The MF-410 features a total of 9 angle settings, including 6 bench incline angles and 3 seat angle variations.



FOLDABLE WITH TRANSPORT WHEELS

Save space and protect your equipment with the MF-410 folding feature. With the assistance of two transportation wheels located on the frame, you'll be able to relocate this bench press in your home gym or studio with ease.

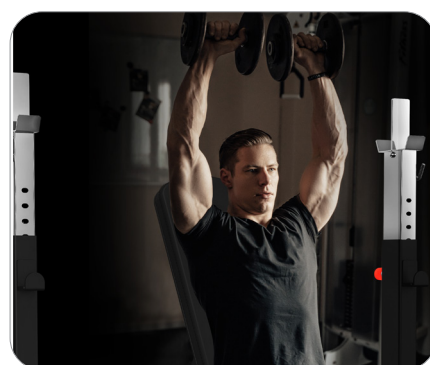

OVERHEAD PRESS

Seat pad slides back to allow for a completely upright seating position, great for overhead press exercises.

MF-4000 MULTI-FUNCTION BENCH PRESS

BENCHMF4000

- Bench Width: 27cm (back rest)/30cm (seat)
- Huge range of exercises that will target your entire body
- Chest: flat, incline and decline bench press
- Shoulders: shoulder press, military press
- Assembled dimensions: 134cm x 115cm x 172cm (L x W x H)



ADJUSTABLE ANGLE
(FLAT / INCLINE)



SAFETY SPOTS



BARBELL
HOOKS



ALPHA SERIES FID-09 COMMERCIAL MULTI ADJUSTABLE BENCH WITH DECLINE

CXST-FID09

- Fully adjustable from decline, flat and incline positions (8 levels)
- Commercial Grade Steel (12-gauge, 2.5mm)
- Transportation Wheels for easy mobility



8 LEVELS OF FLAT,
INCLINE, DECLINE



3 LEVELS SEAT
ADJUSTMENT



SCAN QR FOR
DEMO VIDEO



LEG PRESS



LP1 VERTICAL LEG PRESS

STATIONLP1

Compact leg press compatible with Olympic and standard weight plates.

- Adjustable safety pins
- High density padding
- Back support
- 5 Adjustable levels for user height 160cm to 190cm



COMPATIBLE WITH
STANDARD AND OLYMPIC



200KG MAX WEIGHT



▶
SCAN QR FOR
DEMO VIDEO



LP-10 45 DEGREE LEG PRESS/HACK SQUAT COMBO

CSST-LP10

The 2-in-1 machine offers versatility and comfort to your workout with the removeable cushioned back rest and padded shoulder rest.

- 45 degree leg press
- Removable Back Rest to interchange for Hack Squats
- 4 Weight Storage Pegs, compatible with Olympic weight plates (50mm)



▶
SCAN QR FOR
DEMO VIDEO



ADJUSTABLE
FOOTPLATE



240KG
MAXIMUM WEIGHT



COMPATIBLE WITH
50MM OLYMPIC
WEIGHTS

AVAILABLE IN PACKAGES:

**LP-10 45 Degree Leg Press & Hack Squat +
100kg Olympic Tri-Grip Plate Package**

CSST-LP10-A

01 COMPETITION BUMPER PLATES

Available sizes:

- 5kg CSST-WPOCP05-2
- 10kg CSST-WPOCP10-2
- 15kg CSST-WPOCP15-2
- 20kg CSST-WPOCP20-2
- 25kg CSST-WPOCP25-2

 DESIGNED FOR OLYMPIC LIFTING
  COMMERCIAL GRADED



 SCAN QR FOR DEMO VIDEO



02 BLACK SERIES V2 BUMPER PLATE

Available sizes:

- 5kg CSWP-OBPV205-2
- 10kg CSWP-OBPV210-2
- 15kg CSWP-OBPV215-2
- 20kg CSWP-OBPV220-2
- 25kg CSWP-OBPV225-2

 STEEL RING CORE
  50MM HOLE DIAMETER



03 OLYMPIC TRI-GRIP

Available sizes:

- 1.25kg (4 Pack) CSST-WPOTG012-4
- 2.5kg (2 Pack) CSST-WPOTG025-2
- 5kg (2 Pack) CSST-WPOTG050-2
- 10kg (2 Pack) CSST-WPOTG100-2
- 20kg (1 Pack) CSST-WPOTG200-1

 DESIGNED FOR OLYMPIC LIFTING
  STEEL RING CORE



04 FRACTIONAL PLATES

WPOLYFRAC0065

- Allow for precision loading for consistent progress
- Breakthrough lifting plateaus
- Sold in pack of 6.5kg
- Includes pairs of 0.25kg, 0.5kg, 1kg and 1.5kg

 DESIGNED FOR OLYMPIC LIFTING
  STEEL CONSTRUCTION



OLYMPIC BARS & ACCESSORIES

*Please refer to the website to see weight sets.

01 Spring Collars (Pair)
OLYCOLLARS-SPRING

02 Olympic Lock Jaw Collars (Pair)
OLYCOLLARS-LOCKJAW

03 Olympic Alpha Aluminium Collars
OLYCOLLARSALU

04 Olympic Dumbbell Handles + SC
OLYDBPAIRSCSET

05 Olympic Tri Bar + SC
OLYBBTRISCSET

06 Olympic Hex Deadlift Bar + LC
OLYBBHEXLJCSET

07 Olympic Multi Grip Bar + LC
OLYBBMGRLJCSET

08 Olympic Swiss Bar + LC
OLYBBSWSLJCSET

09 Olympic Curl Bar + SC
OLYBBCBSCSET

10 Safety Squat Olympic Barbell + LC
CXBB-STYSQT-LC

11 Athena 100 79" 15kg Olympic Barbell (Chrome) + SC / LC
CXBB-ATNA100-SC / CXBB-ATNA100-LC

12 Athena 200 86" 15kg Olympic Barbell (Chrome) + LC
CXBB-ATNA200-LC

13 Spartan 100 86" 20kg Olympic Barbell + LC
CXBB-SPTN100-LC

14 Spartan 100 Olympic Barbell (Black Oxide) + LC
CXBB-SN100BO-LC

15 Spartan 205 Olympic Barbell (Hard Chrome) + LC
CXBB-SN205HC-LC

16 Zeus 100 Competition 86" 20kg Olympic Barbell (Chrome) + AC
CXBB-ZEUS100-AC

WEIGHTS | OLYMPIC BARS & WEIGHTS

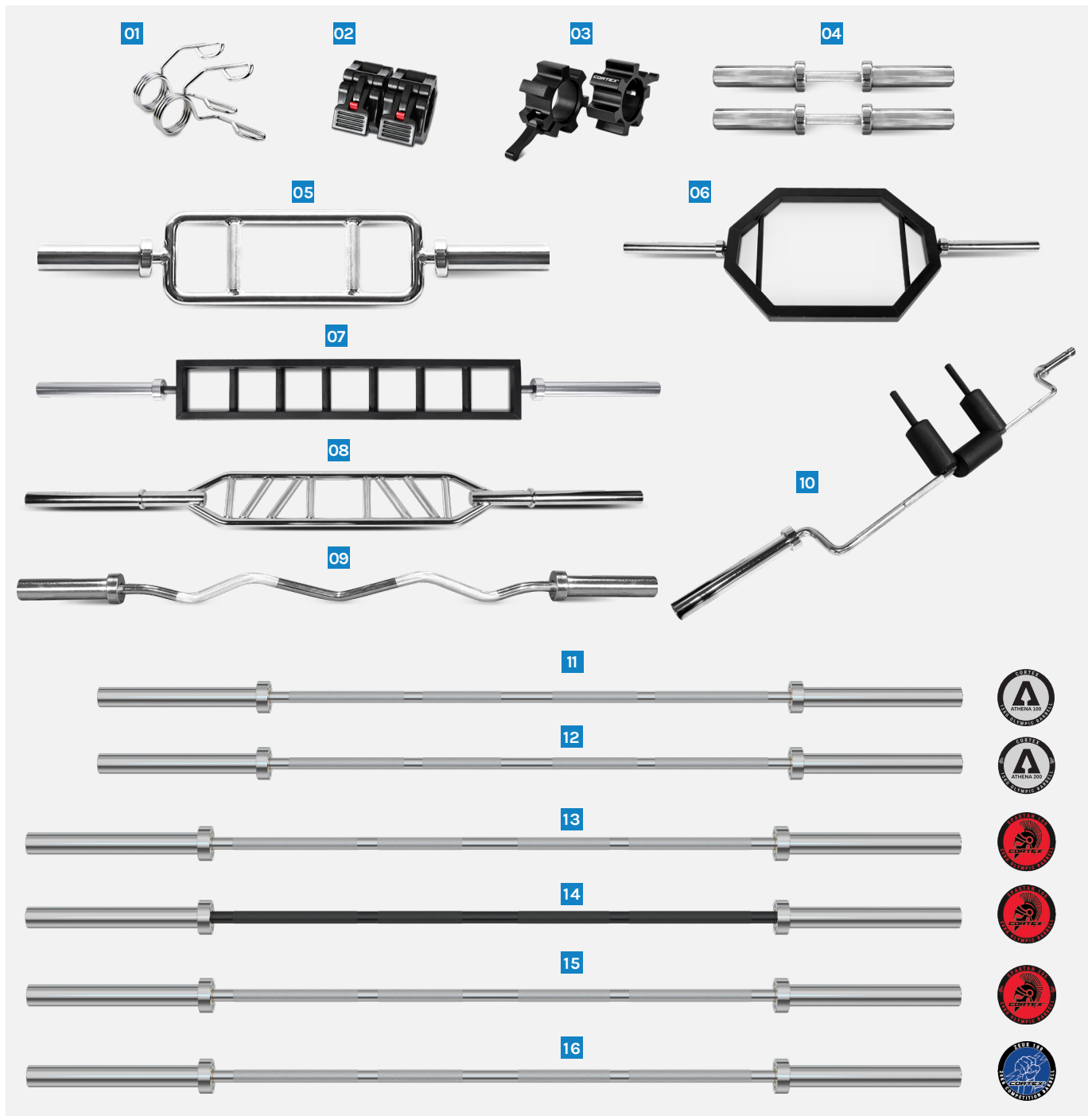



PUMP/STUDIO BARBELL WEIGHT SET 20KG/30KG

STUDIO-WEIGHTSET / CSST-WPSSDO-30

- Studio barbell with rubber grip (35mm grip)
- 8 side anti-roll design plates
- Rubber constructed
- Colour coded for different weights
- Choose between sets of 20kg or 30kg

 30MM HOLE DIAMETER

 SPRING COLLAR CLAMPS INCLUDED



WEIGHT TRAINING ACCESSORIES

WEIGHT LIFTING CHALK

CSACHALKWL

Magnesium chalk for gym, weightlifting, kettlebell or dumbbell. Chalk reduces moisture on hands to improve your ability to maintain grip.

- Pack of 8 (360g)
- 56g per pack



THICK BAR GRIPS (PAIRS)

BARWEIGHTGRIPS-BLACK-PAIR

Turn any barbell or bar into a thicker 50mm diameter handle to improve grip strength and muscle activation.

 50MM DIAMETER  125MM WIDE

 HIGH QUALITY RUBBER



BARBELL SQUAT PAD

BARBELLSQUATPAD

Eliminate pain from heavy, centre-knurled barbells during squats so you can focus on your form and lift heavier without discomfort.

 43CM LONG
10CM WIDE

 ERGONOMICAL DESIGN

 GREAT WORKOUT RANGE

 25MM HOLE



OLYMPIC POST LANDMINE

BARBELLANDMINE-POST

Essential for landmine exercises which unlock a huge variety of pulling, pushing squatting, lunging and rotating in one tool.

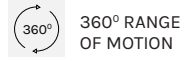

360° RANGE OF MOTION



MAX WEIGHT LOAD: 250KG



FITS 50MM OLYMPIC BARBELLS



SINGLE ARM BARBELL JACK

BARBELLIFTERSA

Compact single-arm deadlift barbell jack to make loading and unloading plates easier.

- Nylon wear pads protect barbell



200KG MAX WEIGHT



RAISES BARBELL TO 310MM



TOASTER RACK 16 PLATE

WTOLYTOAST16

- Keeps floor tidy and allows for easy access
- 16 slots to fit weight plates



HEAVY DUTY STEEL CONSTRUCTION



500KG MAX WEIGHT CAPACITY

150KG Competition Bumper Plates Set with 16 Plate Toaster Rack
CSST-WPOCPSET-D



50MM PARALLEL LANDMINE HANDLE

BARBELLANDMINE-PARH

Paired with the post landmine, the landmine handle unlocks rows for a killer back workout.



SEAMLESS STEEL SLEEVES



STRONG STEEL CONSTRUCTION



FITS 50MM OLYMPIC BARBELLS



DEADLIFT BARBELL JACK

BARBELLIFTER

Spend more energy on lifting weights and less on loading plates with our Deadlift Barbell Jack.

- Allows for easy weight racking and un-racking
- Nylon wear pads protect barbell
- Durable steel construction



150KG MAX WEIGHT



RAISES BARBELL TO 310MM



OLYMPIC WEIGHT TREE

WTOLYMPIC

- 3-tier weight tree
- Designed to fit plate diameter of 450mm
- 2 x Olympic bar/barbell holders



400KG MAX WEIGHT



3 LEVELS OF OLYMPIC WEIGHT STORAGE

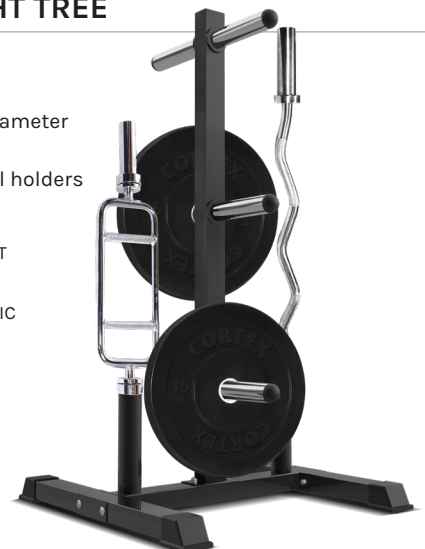

01 ENDURASHELL WEIGHT PLATES

Available sizes:

- 1.25kg CSST-WPSEC012-4
- 2.5kg CSST-WPSEC025-4
- 5kg CSST-WPSEC050-4
- 10kg CSST-WPSEC0100-2



02 CAST IRON TRI-GRIP WEIGHTS

Available sizes:

- 1.25kg CSST-WPSTG012
- 2.5kg CSST-WPSTG025
- 5kg CSST-WPSTG050
- 10kg CSST-WPSTG100
- 20kg CSST-WPSTG200



20KG STANDARD DUMBBELL SET WITH CASE

DBSET20CASE

- Dumbbell handles with rubber grips and spiral lock collars
- Set comes with 4 x 1.25kg and 4 x 2.5kg cast iron plates
- Carry case included



STANDARD WEIGHT TREE

WTSTANDARD

- 3-Tier weight tree
- 2x Standard bar/barbell holders

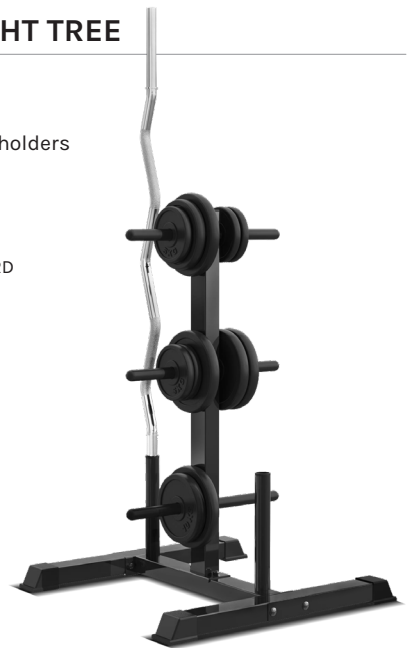
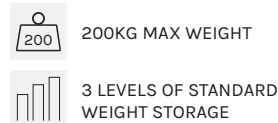

STANDARD BARS

*Please refer to the website to see weight sets.

- 01 Standard Dumbbell Handles** DBSTANDARD14
- 02 Standard Tri Bar** TRIBARSTD
- 03 Standard EZ Curl Bar** CURLBARSTD47
- 04 Standard 6ft Barbell (25mm)** BARBELLSTD72A



OLYMPIC BARBELL HOLDER 9

CSWT-BBH900

- Designed for 50mm sleeves
- Heavy Duty Steel Construction



HOLDS UP TO 9 OLYMPIC BARS



SPACE EFFICIENT



3M X 2M 50MM WEIGHTLIFTING PLATFORM WITH DUAL DENSITY MATS FRAMED SET

CSST-PF30205-A

- 3.0m wide by 2.0m long
- High density rubber tiles (50mm thick) to absorb impact
- 4x Resistance band pegs for band deadlifts



STEEL CONSTRUCTION



50MM THICK MATS

AVAILABLE IN PACKAGES:

3m x 2m 50mm Weightlifting Framed Platform (Dual Density Mats) + 230kg Olympic V2 Weight Plates & Barbell Package
CSST-PF30205-G

3m x 2m 50mm Weightlifting Framed Platform (Dual Density Mats) + 170kg Olympic V2 Weight Plates & Barbell Package
CSST-PF30205-E



VERTICAL BARBELL WALL MOUNT

WTOLYVWALL5

- Heavy duty steel construction
- Space efficient
- Weight loading: 125kg Total

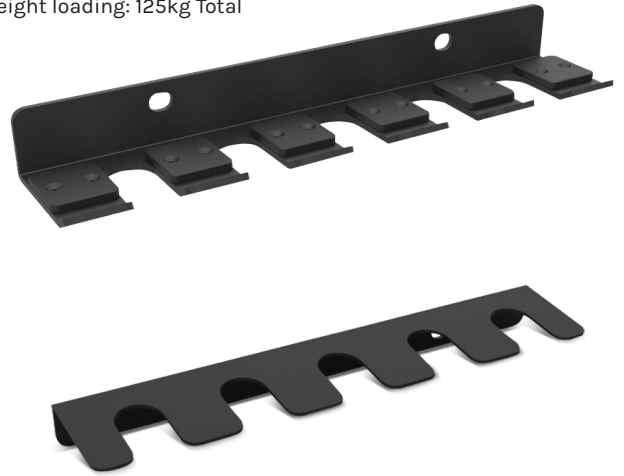

6-TIER WALL BARBELL MOUNT (GUN RACK STYLE)

CSWT-BBHH6

- Fits 6 Barbells
- Plastic Inserts to protect your bars
- Assembled Size: Each Rack - 103cm x 10cm x 4.5cm (L x W x H)



HEAVY DUTY STEEL CONSTRUCTION

3M X 1M 50MM WEIGHTLIFTING PLATFORM WITH DUAL DENSITY MATS SET

CSST-PF30105-A

- 3.0m wide by 1.0m long
- High density rubber tiles (50mm thick) to absorb impact
- 2 piece High density plywood platform



HIGH DENSITY FIBREBOARD PLATFORM



50MM THICK MATS

AVAILABLE IN PACKAGES:

3M X 1M 50mm Weightlifting Platform with Dual Density Mats Set + 90kg Olympic Weight Plates & Barbell Package
CSST-PF30105-B

3M X 1M 50mm Weightlifting Platform with Dual Density Mats Set + 90kg Olympic V2 Weight Plates & Barbell Package
CSST-PF30105-C





COMMERCIAL STEEL KETTLEBELL V2

Available sizes:

- 8kg CXST-KBS2-08
- 10kg CXST-KBS2-10
- 12kg CXST-KBS2-12
- 14kg CXST-KBS2-14
- 16kg CXST-KBS2-16
- 20kg CXST-KBS2-20
- 24kg CXST-KBS2-24
- 28kg CXST-KBS2-28
- 32kg CXST-KBS2-32

01 8kg to 32kg + Stand
CXST-KBS2-B



INDUSTRIAL
GRADE STEEL



HEAVY DUTY
STEEL CONSTRUCTION



8KG TO 32KG STEEL
KETTLEBELL SET

HIGH QUALITY KETTLEBELLS

STANDARD KETTLEBELL

Available sets:

- Kettlebell set 6kg to 16kg KBSTANDARDSET6-16KG
- Kettlebell set 6kg to 12kg CSST-KBSTSET-A

- 6kg KBSTANDARD6
- 8kg KBSTANDARD8
- 10kg KBSTANDARD10
- 12kg KBSTANDARD12
- 16kg KBSTANDARD16



HEAVY DUTY
PLASTIC SHELL



COMFORTABLE
GRIP



ADJUSTABLE KETTLEBELL 10KG

KBADJUST10KG

Our adjustable kettlebell offers 7 possible unique weights between 2kg to 10kg. Ergonomically designed to feel just like using a regular kettlebell, our adjustable kettlebell has authentic weight distribution.



10KG MAX



CAST IRON KETTLEBELLS

- Kettlebell set 4kg to 20kg KBVINYLSET4-20KG
- Kettlebell set 4kg to 12kg KBVINYLSET4-12KG
- 2-Tier kettlebell rack KETTLEBELLRACK2T



VINYL DIP
COATING



GREAT FOR
HOME



COLOUR CODED



SCAN QR FOR
DEMO VIDEO

Available sizes:

- 4kg KBVINYL4
- 6kg KBVINYL6
- 8kg KBVINYL8
- 10kg KBVINYL10
- 12kg KBVINYL12
- 16kg KBVINYL16
- 20kg KBVINYL20



2-TIER KETTLEBELL RACK

KETTLEBELLRACK2T

Our 2-tier kettlebell rack will help store your weights and bars conveniently.



200KG MAX
WEIGHT PER TIER



HEAVY DUTY STEEL
CONSTRUCTION



3-TIER KETTLEBELL RACK

KBRACK3TSET

Designed for gyms or studios, our 3-tier offers more storage for the same space.



200KG MAX
WEIGHT PER TIER



HEAVY DUTY STEEL
CONSTRUCTION



V1 ADJUSTABLE DUMBBELL PAIR

DBADJUST52.5PAIR / DBADJUST52.5PAIR-STAND / DBADJUSTSTAND

- Contoured handle for easy gripping weight system
- Stand is an optional extra
- Change weight in seconds
- Each Dumbbell Adjustable from 2.5kg to 24kg
- Comes in Pairs

ADJUSTABLE FROM 2.5KG TO 24KG

CONTOURED HANDLE FOR EASY GRIPPING

SMART LOCKING SYSTEM



Smart Locking System

With a simple weight selection dial and smart locking system, it takes seconds to pick the right weight for your workout allowing you to spend more time working out and less time switching weights.



REVOLOCK® ADJUSTABLE DUMBBELLS WITH STORAGE STAND

CSST-DBAJ032-2S

- Knurl Gripped Handle
- RevoLock System: Twist Handle to change weight
- Dumbbell becomes smaller as there are less weights
- Stand is an optional extra

32KG PAIR

ADJUSTABLE FROM 2KG TO 32KG

KNURL GRIP HANDLE

SMART LOCKING SYSTEM

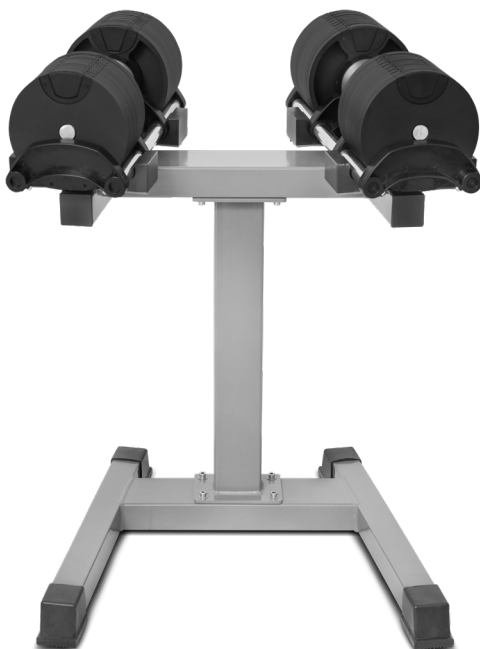

CSST-DBAJ032-2
2 x 32kg
RevoLock Adjustable
Dumbbells

HEX DUMBBELL SET

01 1kg - 10kg (10 Pairs)
CSST-DBHSET-110



STRONG DURABLE
STEEL FRAME

02 4kg - 10kg (4 Pairs)
CSST-DBHSET-56

03 Hex Fixed Dumbbell Stand
(Suitable for 1-10kg Pairs)
CSST-DBHSTND110



1KG TO 3KG 3-PAIR DUMBBELL SET WITH STAND

CSAC-DBVNY-12

- Vinyl Dipped & Colour coded
- Easy to handle
- Smooth consistent grip
- Comes with 3-tier Stand



12KG TOTAL
WEIGHT



STAND
INCLUDED



PRO-FIXED DUMBBELLS WITH 2-TIER RACK

DBPRO2SET5-30KG

- Heavy duty commercial grade dumbbells
- Rubber pro-style with weight (kg) embossed
- Knurl grip handles
- 2-Tier dumbbell rack



RANGE FROM
5KG TO 30KG



12 PAIRS OF
DUMBBELLS



WOODEN 3-IN-1 MULTI PLYO BOX

PLYOBOXWOOD3IN1

- Roll over to adjust 3 different heights (51cm, 61cm, 76cm)
- Side handles for easy mobility



STEEL PLYO BOX

PLYOBOX30-BK PLYOBOX60-BK
 PLYOBOX45-BK PLYOBOX3SET-BK

The original plyometric box. Steel frame for exceptional durability and strength. Rubber slip resistant platform and rubber feet for safety and stability.



SOFT 3-IN-1 MULTI PLYO BOX

PLYOBOX-3IN1

- Capable of adjustment to 3 different heights (51cm, 61cm, 76cm), to allow for progressive exercises.
- Soft structure to cushion accidental falls
- Ultra-high density foam



SOFT PLYO BOX STACKING SET

PLYOBOXSOFT-SET

- Set comes with 15cm, 30cm, 45cm, 60cm tall plyometric foam boxes
- Base size: 90cm x 75cm (L x W)
- Soft structure to cushion accidental falls
- Stack on Plyo Boxes to combine box heights
- Velcro Tabs to attach boxes together



MEDICINE BALLS

Our rubber medicine balls are great for developing strength, power, endurance, and are suitable for all levels of abilities and ages.

Available sizes:

- 2kg MEDBALL2
- 4kg MEDBALL4
- 6kg MEDBALL6
- 8kg MEDBALL8
- 10kg MEDBALL10

AVAILABLE IN PACKAGES:

- Medicine ball rack MEDBALLRACK10
- Medicine ball 28kg set MEDBALLSET28
- Medicine ball 30kg set MEDBALLSET30
- Medicine ball 60kg set + Stand MEDBALLSET60S



WALL BALLS

Great for drills to improve weightlifting movements, train strength and target multiple muscle areas.

Available sizes:

- 4kg WALLBALL-4KG
- 6kg WALLBALL-6KG
- 8kg WALLBALL-8KG
- 10kg WALLBALL-10KG

AVAILABLE IN PACKAGES:

- Wall ball complete 28kg set WALLBALLSET28



SLAM BALL

Available sizes:

- 6kg CSST-SBLV2-06
- 8kg CSST-SBLV2-08
- 10kg CSST-SBLV2-10
- 12kg CSST-SBLV2-12
- 15kg CSST-SBLV2-15
- 20kg CSST-SBLV2-20
- 25kg CSST-SBLV2-25
- 30kg CSST-SBLV2-30

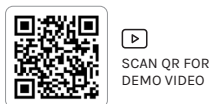

AVAILABLE IN PACKAGES:

- 6-12kg CSST-SBLV2-0612
- 6-30kg CSST-SBLV2-0630

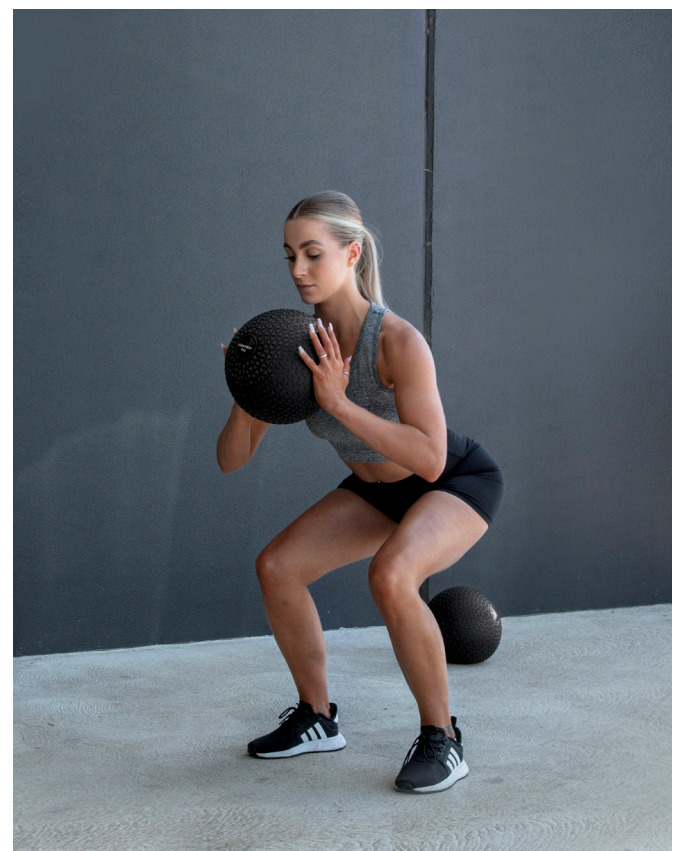

POWER BAGS

Power bags are an excellent conditioning tool and the soft construction of the bag allows for a safe, effective functional way to train.

Available sizes:

- 5kg POWERBAGX-05KG
- 10kg POWERBAGX-10KG
- 15kg POWERBAGX-15KG
- 20kg POWERBAGX-20KG
- 25kg POWERBAGX-25KG

AVAILABLE IN PACKAGES:

- Power bag complete 75kg set POWERBAGXSET75
- Power bag complete 75kg set + Stand POWERBAGXSET75S



COLOUR CODED FOR DIFFERENT WEIGHTS



HEAVY DUTY PU LEATHER



SCAN QR FOR DEMO VIDEO



STRONGMAN SANDBAG FULL SET (45KG, 70KG, 90KG)

Suitable for professional or home use our Strongman Sandbag Full Set can be utilised in cross training, tactical fitness and military conditioning. Sand not included.

Available sizes:

- 45kg CSST-SSB-45
- 70kg CSST-SSB-70
- 90kg CSST-SSB-90

AVAILABLE IN PACKAGES:

- Strongman Sandbag Full Set CSST-SSB-A



45KG, 70KG, 90KG WEIGHTS



HEAVY DUTY MATERIALS



MEDICINE BALL RACK

MEDBALLRACK10

Able to store up to 10 medicine balls or other fitness accessories.



HOLDS UP TO 10 MEDICINE BALLS



STRONG DURABLE STEEL FRAME



*Medicine Balls not included

5-TIER POWER BAG RACK

POWERBAGRACK5

Keep your power bags stored neatly and in order with our 5-tier power bag rack.



5 TIER STORAGE



STRONG DURABLE STEEL FRAME



*Power Bags not included



PLATE LOADED WEIGHT VEST

CSAC-WVESTPL

- Condura Style Heavy Duty Fabric
- Comfortable mesh liner
- Quick Buckle Adjustable shoulder straps
- Hook and loop fasteners for Under-arm
- Spinlock Collars included
- Compatible with 50mm Olympic Weight Plates



130KG MAXIMUM WEIGHT LOAD



COMPATIBLE WITH OLYMPIC WEIGHT PLATES

AVAILABLE IN PACKAGES:

Plate Loaded Weight Vest with 35kg Tri-Grip Olympic Plate Package
CSAC-WVESTPL-A

10KG WEIGHT VEST

WEIGHTVEST-10KG

- Quick release buckle
- Mesh back pocket
- Easy to equip



10KG TOTAL WEIGHT



20KG ADJUSTABLE WEIGHT VEST

CSAC-WVEST-20

- Hook and loop fasteners for Weight pouch
- Hook and loop fasteners for Waist strap
- Made from Dupont fabric and foam
- Length of Vest: 42cm



1KG PER WEIGHT PACK



SLEEVED BATTLE ROPE 38MM X 15M

CSAC-BRSVD-3815

- Variety in training
- Sleeved for longevity



HIGH DENSITY NYLON



15M LONG, 38MM DIAMETER



PARALLEL BARS

BARSPARALLELA

Simple, portable, extremely versatile and highly multi-purpose to work arms, chest, back and core muscles.

- Comes in Pairs



200KG MAX WEIGHT



SOFT GRIP HANDLES



HEIGHT ADJUSTABLE



AB ROLLER WHEEL

ABROLLER

- Great for ab/core workout
- Knee pad included



ERGONOMIC RUBBER HAND GRIPS



HIGH GRADE TPE MATERIAL



LIGHTWEIGHT AND COMPACT



SPEED SKIPPING ROPES

- Precision ball bearings and steel head
- 3.0m coated and adjustable cable

Available sizes:

- Black SKIPROPE-BK
- Silver SKIPROPE-SIL2



ALUMINIUM KNURL GRIPPED HANDLES



TPU COATED SKIPPING CABLE



GYM RING PAIR 28MM

CSAC-GYMRNG2-28

- Easy to adjust and secure, ready for a variety of workouts.
- Crafted with commercial quality straps and wooden rings.
- Comes in Pairs
- Measurements on straps



400KG MAX WEIGHT



CRAFTED AND BUILT TO FIG STANDARDS

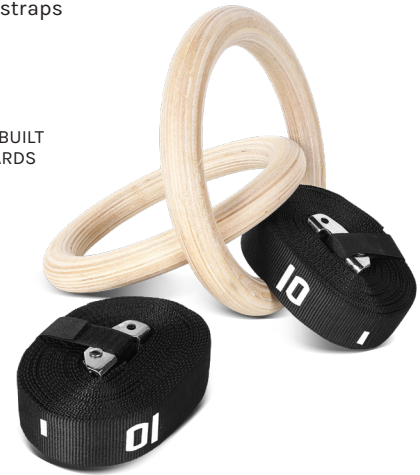

REVOBOUNCE FITNESS TRAMPOLINE

TRMINI40-2

Our RevoBounce trampoline will burn heaps of calories while toning quads, glutes and calves for fun-packed aerobic workout.

- Comes with resistance bands to intensify and add variation to your workout.



40" DIAMETER



STEEL ZINC PLATED SPRINGS



HEIGHT ADJUSTABLE HANDLE



01 RESISTANCE BANDS AND HANDLE

BANDRESISTHANDLE

- Handles provide extra grip on pulling exercises
- Steel construction for strength and durability
- More natural grip for most movements



PRECISE KNURL GRIPPING



CHROME PLATING

02 RESISTANCE BANDS

Purchase separately or in sets:

- Set of 5 BANDRESIST-SET5
- Set of 5 and Handles BANDRESIST-SET5HANDLE
- Set of 10 BANDRESIST-SET10

Available colours and sizes

- 5mm (red) - up to 10kg resistance
- 13mm (blue) - up to 15kg resistance
- 21mm (purple) - up to 30kg resistance
- 32mm (orange) - up to 45kg resistance
- 45mm (green) - up to 60kg resistance



COLOUR CODED



MICRO WIDE RESISTANCE BANDS

CSAC-RBD37-5

- Small 60cm Diameter
- Suited towards prehab, activation and warm up drills
- Up to a maximum of 20kg resistance
- Pack of 5



COLOUR CODED



SCAN QR FOR DEMO VIDEO



FIBRABANDS FABRIC PREMIUM BANDS

CSAC-RBDFB082-3

- Premium Non-Slip Fabric
- For isolated training sessions, great for glutes and lower body workouts
- Up to a maximum of 36kg resistance
- Pack of 3



COMPACT & CONVENIENT



SCAN QR FOR DEMO VIDEO



RESISTANCE BAND & BELT HANGER

BANDHOOK16

- Lightweight steel construction
- Mount to reinforced wall
- 16 Hooks for belts or bands





MULTI LEVEL AEROBIC STEP

CXAC-CTXSTEP

- Made from PP and TPR
- 200kg Max Weight
- Adjustable Height: 9cm, 15.5cm, 20cm



HEIGHT ADJUSTABLE TO 3 POSITIONS



NON-SLIP SURFACE



▶ SCAN QR FOR DEMO VIDEO

5 Level Multi Level Aerobic Step
CXAC-CTXSTEP-5

AB WORKOUT SUPPORT MAT

CSAC-MATAB

- Great for abdominal exercises
- PU & EPE Material
- Portable, compact and lightweight
- High Density Foam



HIGH DENSITY FOAM



PORTABLE, COMPACT AND LIGHTWEIGHT



GRIDSOFTEPP FOAM ROLLER & MASSAGE BALL SET (33CM)

CSAC-FRL3314-HH

- 2-in-1 Massage Ball and Foam Roller
- Made from High Density EPP Foam
- Multiple Trigger Points



33CM TOTAL LENGTH



HIGH QUALITY EVA FOAM



WALL MOUNT EXERCISE MAT HANGER

CSAC-MATWALLH

- Steel construction
- Two rods (23cm long) designed for mats with eyelets
- Powder coated for durability





FITNESS BALL

- Anti-burst material
- Air pump included

Available sizes

- 55cm Grey FITNESSBALL55-GY
- 75cm Grey FITNESSBALL75-GY



EXTREMELY
VERSATILE



SUPER STRONG
ANTI-BURST MATERIAL



UV RESISTANT
MATERIAL

RUBBER GYM FLOOR MAT 50MM

CSAC-MATDD50-1

- Protects flooring and absorbs vibrations
- 100cm x 100cm x 50mm (L x W x H)
- Top Layer: 950kg/m³ Bottom Layer: 850kg/m³
- Approx 42.3kg per mat



PASSES FIRE TEST
FOR FLOORING



RECYCLED RUBBER
GRANULES



50MM
THICKNESS



RUBBER GYM FLOOR MAT 10MM / 15MM

MATGYM10 / MATGYM15

- Protects flooring and absorbs vibrations
- 100cm x 100cm (L x W)
- 10mm/15mm: 933kg/m³ density



PASSES FIRE TEST
FOR FLOORING



RECYCLED RUBBER
GRANULES



10MM / 15MM
THICKNESS

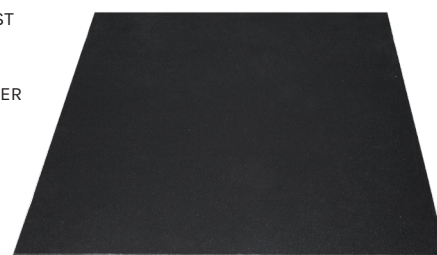

INTERLOCKING RUBBER GYM FLOOR MAT 10MM

CSAC-MATIN10-1

- Protects flooring and absorbs vibrations
- 100cm x 100cm (L x W)
- 950kg/m³ density



PASSES FIRE TEST
FOR FLOORING



RECYCLED RUBBER
GRANULES



98CM
LENGTH

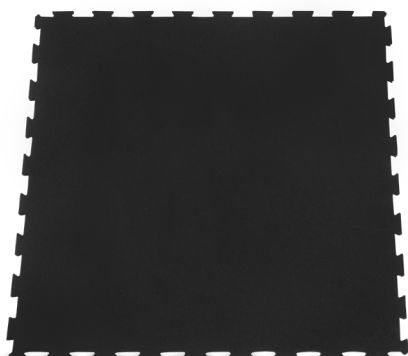

FOLDING EXERCISE MAT 50MM

MATEXFOLDING

A great accessory, perfect for any type of work or stretching routine, pilates, gymnastics and any sort of general fitness.

Assembled size: 180cm x 60cm x 5cm (L x W x H)

Folded size: 60cm x 60cm x 15cm (L x W x H)



5CM THICK
PADDED MAT



FOLDABLE



Lifespan Fitness makes every effort to maintain the accuracy and quality of the information provided on this catalogue. However, Lifespan Fitness cannot guarantee and assumes no legal liability or responsibility for the accuracy or completeness of the information provided. The information contained on this catalogue is for general guidance only.

The copyright of all content on this catalogue is owned by Global Fitness and Leisure and/or the various manufacturers of our equipment. No part of the Lifespan Fitness catalogue may be changed, reproduced, stored in or transmitted on any website or medium without the prior written permission of Lifespan Fitness. Requests to republish any material must be sent to info@lifespanfitness.com.au.